

## Materials, per kite

- Two pieces of 11" x 17" bond paper, for downloading template
- Two 18-inch bamboo spars. You can use lightweight bamboo skewers from the grocery or garden store, but you may need to tape two skewers together for length.
- Kite line and winder
- Scissors
- Scotch tape

**1**

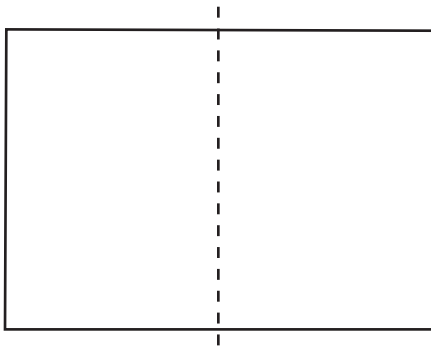

Download template to two pieces of 11" x 17" bond paper: kite sail and tail sections on one piece, loop tail pieces on the other. Fold the first piece of paper in half, as indicated.

**2**

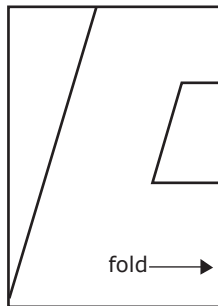

Cut out kite sail and tail pieces on dotted lines, where indicated. Cut out trapezoidal vent in the middle of the sail and discard.

**3**

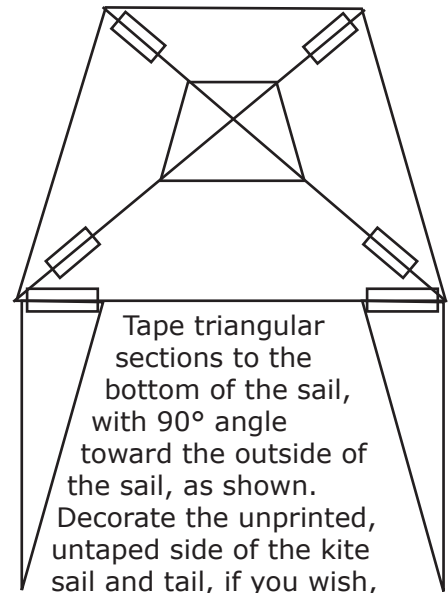

Tape triangular sections to the bottom of the sail, with 90° angle toward the outside of the sail, as shown. Decorate the unprinted, untaped side of the kite sail and tail, if you wish, with markers, crayons, paint, or collage. But remember: keep it light; weight affects flight.

On the back (taped, undecorated) side of the sail, tape the spars in place, as shown.

**4**

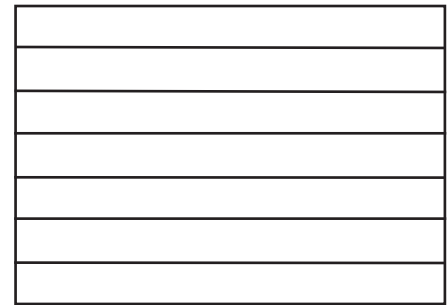

Cut lengthwise strips, as shown, from the second piece of 11" x 17" bond paper. Tape the pieces end to end to make a long tail. Tape this tail to the ends of the triangular sections, as shown below, to make a long loop.

**5**

Turn the kite over so the front (decorated) side faces up. Tie kite line securely around the spars, where they cross in the middle of the vent. Use two overhand (shoelace-style) knots.

